

Introduction

The CO₂ detector uses Infrared Technology to monitor CO₂ levels within a range of 0 – 2000 ppm. Options include a control relay, RH and temperature sensors.

The device includes native ModBus protocol with an RS-485 MS/TP network connection to offer a single-point solution for control of indoor air quality and comfort. Features include a back-lit LCD and user menu for easy installation.

Before Installation

Read these instructions carefully before installing and commissioning the CO₂ detector. Failure to follow these instructions may result in product damage.

Do not use in an explosive or hazardous environment, with combustible or flammable gases, as a safety or emergency stop device or in any other application where failure of the product could result in personal injury.

Take electrostatic discharge precautions during installation and do not exceed the device ratings.

Set-up

The device parameters must be set before connection to the network and will ensure each device will have a unique ModBus address for startup. Once set, all parameters are saved in non-volatile memory.

The local menu and LCD are used to set the ModBus device address (1-255) and the baud rate. The factory defaults are address 01 and 9600 baud. The menu and setup procedure is described in the Start-up section.

Mounting

The duct type sensor installs on the outside of a return air duct with the sampling tube inserted into the duct. Use the included foam plug to prevent air from entering the enclosure through the conduit and causing an incorrect reading.

Mount the sensor in an easily accessible location in a straight section of duct at least five feet from corners and other items that may cause disturbances in the air flow. Avoid areas where the detector is exposed to vibrations or rapid temperature changes.

The duct CO₂ detector principal of operation is based on the Venturi effect of the probe that extends into the HVAC duct. Air flowing through the duct is forced into the vent holes on one side of the probe, into the enclosure, over the CO₂ sensor and then is drawn back out of the enclosure via the probe vent holes on the opposite side.

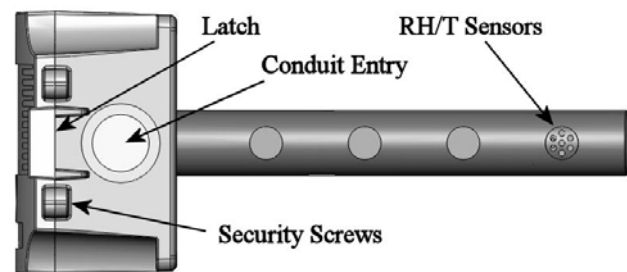

Drill or punch a 1-1/8" or 1-1/4" hole in the duct at the preferred location and insert the probe into the hole to mark the enclosure mounting holes. Remove the unit and drill the four mounting holes. Clean all drilled holes of debris before mounting the device.

Mount the enclosure to the duct with four sheet metal screws such that the duct air flow is parallel with the vent holes in the probe (i.e.: air flows directly into the probe holes). To prevent air leaks, ensure the gasket is compressed around the probe between the device enclosure and the air duct.

Open the cover by releasing the latch and connect the device according to the wiring instructions. After wiring and setup are complete, close and latch the cover. Secure it with two self-tapping screws in the holes provided.

The mounting hole locations are shown in the enclosure dimensional drawing.

Wiring

Deactivate the 24 Vac/dc power supply until all connections are made to the device to prevent electrical shock or equipment damage. Follow proper electrostatic discharge (ESD) handling procedures when installing the device or equipment damage may occur.

Use 22 AWG shielded wiring for all connections and do not locate the device wires in the same conduit with wiring used to supply inductive loads such as motors. Make all connections in accordance with national and local codes.

Connect the 24 Vac/dc power supply to the terminals labeled **POWER** and **COMMON**. Use caution if 24 Vac power is used and one side of the transformer is earth-grounded. In general, the transformer should NOT be connected to earth ground when using devices with RS-485 network connections. The device is reverse voltage protected and will not operate if connected backwards.

Connect the RS-485 network with twisted shielded pair to the terminals marked **A(-)**, **B(+)** and **SHIELD**. The positive wire connects to **B(+)** and the negative wire connects to **A(-)** and the cable shield must be connected to the **SHIELD** terminal on each device.

If the device is installed at either end of an RS-485 network, an end-of-line (EOL) termination resistor (121 ohm) should be installed in parallel to the A(-) and B(+) terminals. This device includes a network termination jumper and will connect the 121 ohm resistor correctly on the pcb.

Simply move the jumper to the EOL position and no external resistor is required. The ground wire of the shielded pair should be connected to earth ground at the end of the network and the master is not grounded.

Do not run bus wiring in the same conduit as line voltage wiring or other wiring that switches power to highly inductive loads such as contactors, coils or motors.

A network segment is a single shielded wire loop run between several devices (nodes) in a daisy chain configuration. The total segment length should be less than 4000 feet (1220 meters) and the maximum number of nodes on one segment is 255. Nodes are any device connected to the loop and include controllers, repeaters and sensors such as the CDD but do not include the EOL terminators.

To install more than 255 devices, or to increase the network length, repeaters will be required for proper communication. The maximum daisy chain length (segment) depends on transmission speed (baud rate), wire size and number of nodes. If communication is slow or unreliable, it may be necessary to wire two daisy chains to the controller with a repeater for each segment.

An optional signal is the relay output available on the **N.O. RELAY** terminals. The relay output is completely isolated and has a Normally Open (NO) signal. This signal can be used to directly control an alarm or ventilation fan.

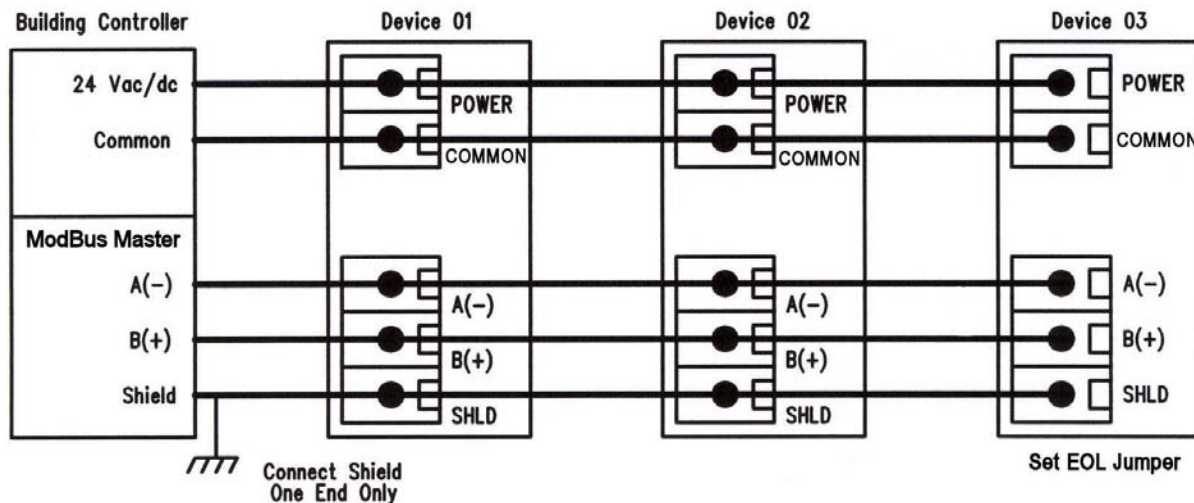

Start-up

Verify the device is properly wired and connections are tight. Apply power and note that the CO2 sensor chamber light flashes on and off. The LCD will indicate the software version number, the Auto Cal status, the ModBus address and the Baud Rate. The device will begin reading the sensor values and display them on the LCD. The sensor operates on a 4 second interval and will update the output and display every 4 seconds.

Operation

In normal operation the device reads the CO2, RH and temperature sensors and updates the register values accordingly. The LCD displays the sensor values as determined by the display mode register.

Modbus Introduction

Modbus is a network protocol for industrial manufacturing environments. The detector communicates on a standard Modbus network using either of two transmission modes: RTU (Remote Terminal Unit) or ASCII (American Standard Code for Information Interchange). The hardware interface is RS-485. Select the desired mode along with the other parameters using the Setup Menu.

Modbus Trouble-shooting

The CO2/RH/T device operates as a slave. It will not communicate unless a master is connected to the network and sends a request for information, then the slave will answer. If the device does not communicate properly, first check that the communication wires are not reversed. Then check the communication parameters in the menu in the following sequence: Slave address, baud rate, transmission mode, parity bit, stop bit, RTU mode CRC polynomial and slave response delay.

The factory default Modbus address is 01 and each device must have its unique address to communicate properly on the bus. Use the menu as described above to change the Slave address to a unique number for each unit.

The default Modbus baud rate is 9600. Use the menu as described above to change the baud rate to the correct setting.

The default transmission mode is RTU. If this is incorrect, use the menu to change the transmission mode to ASCII.

The default Modbus parity is N for None. If this is not correct, use the menu to change the parity from None to Odd or Even.

The default stop bits is 1. Use the menu to change the stop bit setting to 2. For some configurations the value is fixed.

The default Modbus CRC value is A001. The menu can be used to change this setting. This only applies to RTU mode and has no effect in ASCII mode. It is the CRC polynomial setting and can be changed between A001, 1021, 8005 or 8408.

The default Modbus delay is minimum (0). This can be changed as described above. It is the slave response delay and can be set from minimum to 350ms. For example, the minimum delay means 3.5 character time delays or 4ms for 9600 baud rate.

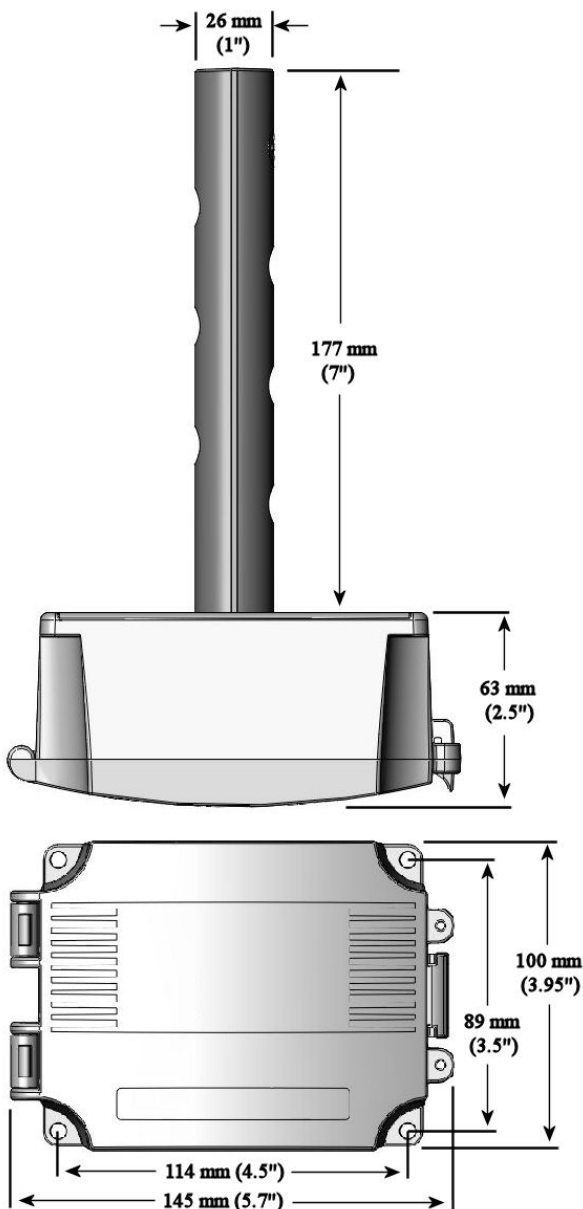

Setup Menu

The menu has several items shown below. To enter the menu, press and release the <MENU> key. This will enter the SETUP menu step 1, pressing <MENU> again advances to step 2. Each press of the <MENU> key advances the menu item. No values are saved by using the <MENU> key. The <UP> and <DOWN> keys are used to make changes to variables by scrolling through the available options. Use the <SAVE> key to save changes to memory and advance to the next menu item.

<MENU> Press and release the <MENU> key to enter the SETUP menu

1. ModBus Addr 01 Use the <UP> or <DOWN> keys to select a unique slave address from 1-255. Press the <SAVE> key to save the change. The factory default ModBus slave address is 1.

<MENU>

2. BaudRate 9600 Use <UP> or <DOWN> to select a baud rate of 300, 600, 1200, 2400, 4800, 9600, 19200, 38400, 57600, 76800 or 115200. Use the <SAVE> key to save the change. The factory default ModBus baud rate is 9600.

<MENU>

3. Mod Mode RTU Use the <UP> or <DOWN> keys to toggle between RTU and ASCII modes. Press the <SAVE> key to save the change. The factory default ModBus transmission mode is RTU.

<MENU>

4. ModBus Parity N Use the <UP> or <DOWN> keys to select a parity value of N (none), O (odd) or E (even). Press the <SAVE> key to save the change. The factory default ModBus parity bit is N (none).

<MENU>

5. ModBus Stop 1 Use the <UP> or <DOWN> keys to toggle the stop bits between 1 and 2 (*for some configurations the value is fixed*). Press the <SAVE> key to save. The default stop bits is 1.

<MENU>

6. ModBus CRC A001 Use <UP> or <DOWN> keys to select a CRC value of A001 (CRC-16 reverse), 1021 (CITT), 8005 (CRC-16) or 8408 (CITT reverse). Press the <SAVE> key to save the value. The default RTU mode CRC polynomial is 0XA001.

<MENU>

7. ModBus Del MI Use the <UP> or <DOWN> keys to change the value from MI (minimum) to 50, 100, 150, 200, 250, 300 or 350ms. Press the <SAVE>key to save the value. The factory default slave response delay is MI (*minimum delay means just more than 3.5 character time delays, 4ms for 9600 baud rate, for example*).

<MENU>

8. Calibrat 1000 PPM This item is used for 1000 ppm gas calibration and is explained in the *Calibration* section.

<MENU>

Item 9 is only available if the Relay Option is installed, otherwise the menu skips directly to step 10.

9. Relay Test OFF Use the <UP> or <DOWN> keys to toggle the relay ON or OFF. Press the <MENU> key to turn the relay off and advance to the next item.

<MENU>

10. BackLite Enable Use <UP> or <DOWN> to enable or disable the LCD backlight. When enabled the backlight is always on, when disabled it never lights. Press the <SAVE> key to save the setting. The default is Enable.

<MENU>

- 11. Menu Exit Press <SAVE> to exit the menu and return to normal operation or <MENU> to repeat the menu.

ModBus Protocol

This section describes the implementation of the Modbus protocol used in the CO2/RH/T detector. It is intended to assist control system programmers who may need to add support to their systems to communicate with this device. The CO2/RH/T detector communicates on standard Modbus networks using either RTU or ASCII mode transmission. It operates as a slave device (address from 01 to 255) and expects a Modbus master device to transmit queries, which it will answer.

RTU Mode Message Format

Modbus Framing	8 bit binary
Data Bits	start bits --- 1 data bits --- 8 parity bits --- none, odd or even stop bits --- 1or 2
Baud Rate	300, 600, 1200, 2400, 4800, 9600, 19200, 38400, 57600, 76800 or 115200
Duplex	Half duplex
Error Checking	Cyclical Redundancy Check (CRC) CRC-16 --- polynomial $x^{16}+x^{15}+x^2+x^0$ 0x8005 or reversed version 0xA001 or CRC-CITT --- polynomial $x^{16}+x^{12}+x^5+x^0$ 0x1021 or reversed version 0x8408
Latency	More than 3.5 characters --- minimum, 50, 100, 150, 200, 250, 300 or 350 mS

ASCII Mode Message Format

Modbus Framing	ASCII characters 0...9, A...F
Data Bits	start bits --- 1 data bits --- 7 parity bits --- none, odd or even stop bits --- 1or 2
Baud Rate	300, 600, 1200, 2400, 4800, 9600, 19200, 38400, 57600, 76800 or 115200
Duplex	Half duplex
Error Checking	Longitudinal Redundancy Check (LRC)
Latency	More than 3.5 characters --- minimum, 50, 100, 150, 200, 250, 300 or 350 mS

Framing Support and Bit Sequences

RTU Mode	Start	1	2	3	4	5	6	7	8	Stop	
	Start	1	2	3	4	5	6	7	8	Stop	Stop
	Start	1	2	3	4	5	6	7	8	Odd	Stop
	Start	1	2	3	4	5	6	7	8	Even	Stop
ASCII Mode	Start	1	2	3	4	5	6	7	Stop	Stop	
	Start	1	2	3	4	5	6	7	Odd	Stop	
	Start	1	2	3	4	5	6	7	Odd	Stop	Stop
	Start	1	2	3	4	5	6	7	Even	Stop	
	Start	1	2	3	4	5	6	7	Even	Stop	Stop

Modbus Register Addressing

Modbus Address	Typical Offset	Units	Data Type	Access	Notes
40001	+0		Bit	Read	Unsigned 16-bit integer Bit0 1 = CO2 in normal status, 0 = in abnormal status, Bit1-15 unused
40002	+1	PPM	Word	Read	Unsigned 16-bit integer, CO2 value
40003	+2	%RH	Word	Read	Unsigned 16-bit integer, %RH value
40004	+3	°F/°C	Word	Read	Unsigned 16-bit integer, Temperature value x 10 *
40005	+4		Word	Read	Unsigned 16-bit integer 1 = relay activated, 0 = relay not activated
40006	+5	Feet	Word	Write	Unsigned 16-bit integer, SENSOR_ALTITUDE = 0 to 0x0A ALTITUDE = 500 * (SENSOR_ALTITUDE) = 0 to 5000 feet
40007	+6		Word	Write	Unsigned 16-bit integer 1 = auto cal on, 0 = auto cal off
40008	+7		Word	Write	Unsigned 16-bit integer 1 = degrees F, 0 = degrees C
40009	+8		Word	Write	Unsigned 16-bit integer, DISPLAY_MODE = 0 to 0x03 0=CO2, 1=CO2+RH, 2=CO2+T, 3=CO2+RH+T
40010	+9	°F	Word	Write	Unsigned 16-bit integer, TEMPERATURE_OFFSET = 0 to 0x0A T_OFFSET = TEMPERATURE_OFFSET - 5 = -5 to +5 °F
40011	+10	%RH	Word	Write	Unsigned 16-bit integer, RH_OFFSET = 0 to 0x14 RH_OFF = RH_OFFSET - 10 = -10 to +10 %RH
40012	+11	PPM	Word	Write	Unsigned 16-bit integer RELAY_SETPOINT = 0x1F4 to 0x5DC = 500 to 1500 ppm
40013	+12	PPM	Word	Write	Unsigned 16-bit integer RELAY_HYSTERESIS = 0x19 to 0xC8 = 25 to 200 ppm

* Note that °C and °F integer values are used to represent a floating point number. Therefore the multiplier for these values is 10. The application program must divide the value by 10 to obtain the correct value. For example, reading a temperature value of 214 °C actually represents 214/10 = 21.4 °C.

Function Codes (RTU mode)

0x01 --- Read coil status

Query

Slave address (0x01 to 0xFF)	Function code (0x01)	Starting address MSB *	Starting address LSB	Quantity of coils MSB *	Quantity of coils LSB	CRC LSB	CRC MSB
------------------------------	----------------------	------------------------	----------------------	-------------------------	-----------------------	---------	---------

* Starting address = 0x0000 to 0xFFFF, Quantity of coils = 0x0000 to 0x07D0

Response

Slave address (0x01 to 0xFF)	Function code (0x01)	Byte count N*	Coil status MSB	...	Coil status LSB	CRC LSB	CRC MSB
------------------------------	----------------------	---------------	-----------------	-----	-----------------	---------	---------

* N= Quantity of coils /8 or Quantity of coils /8 +1 (if the remainder is not 0)

0x03 --- Read holding registers

Query

Slave address (0x01 to 0xFF)	Function code (0x03)	Starting address MSB *	Starting address LSB	Quantity of registers MSB *	Quantity of registers LSB	CRC LSB	CRC MSB
---------------------------------	-------------------------	---------------------------	-------------------------	--------------------------------	------------------------------	------------	------------

* Starting address = 0x0000 to 0xFFFF, Quantity of registers = 0x0000 to 0x007D

Response

Slave address (0x01 to 0xFF)	Function code (0x03)	Byte count 2N *	Register value MSB	Register value LSB	...	CRC LSB	CRC MSB
---------------------------------	-------------------------	--------------------	-----------------------	-----------------------	-----	------------	------------

* N= Quantity of registers

0x06 --- Write single register

Query

Slave address (0x01 to 0xFF)	Function code 0x06	Register address MSB *	Register address LSB	Register value MSB *	Register value LSB	CRC LSB	CRC MSB
---------------------------------	-----------------------	---------------------------	-------------------------	-------------------------	-----------------------	------------	------------

Response

Slave address (0x01 to 0xFF)	Function code 0x06	Register address MSB *	Register address LSB	Register value MSB *	Register value LSB	CRC LSB	CRC MSB
---------------------------------	-----------------------	---------------------------	-------------------------	-------------------------	-----------------------	------------	------------

* Register address = 0x0000 to 0xFFFF, Registers value = 0x0000 to 0xFFFF

Exception response

Slave address (0x01 to 0xFF)	Function code + 0x80	Exception code * 0x01, 0x02 or 0x03	CRC LSB	CRC MSB
---------------------------------	-------------------------	----------------------------------------	------------	------------

* An exception response is only returned if the CRC is correct
Exception code 01 --- illegal function, 02 --- illegal address, 03 --- illegal data value

The RTU function codes supported by the CO2/RH/T are shown below.

0x01 --- Read CO2 Status

Query

Slave address (0x01 to 0xFF)	0x01	0x00	0x00	0x00	0x01	CRC LSB	CRC MSB
---------------------------------	------	------	------	------	------	------------	------------

Response

Slave address (0x01 to 0xFF)	0x01	0x01	Coil Status value	CRC LSB	CRC MSB
---------------------------------	------	------	----------------------	------------	------------

0x03 --- Read CO2 PPM

Query

Slave address (0x01 to 0xFF)	0x03	0x00	0x01	0x00	0x01	CRC LSB	CRC MSB
---------------------------------	------	------	------	------	------	------------	------------

Response

Slave address (0x01 to 0xFF)	0x03	0x02	Register value MSB (PPM)	Register value LSB (PPM)	CRC LSB	CRC MSB
---------------------------------	------	------	-----------------------------	-----------------------------	------------	------------

0x03 --- Read %RH

Query

Slave address (0x01 to 0xFF)	0x03	0x00	0x02	0x00	0x01	CRC LSB	CRC MSB
---------------------------------	------	------	------	------	------	------------	------------

Response

Slave address (0x01 to 0xFF)	0x03	0x02	Register value 0x00	Register value (%RH)	CRC LSB	CRC MSB
---------------------------------	------	------	------------------------	-------------------------	------------	------------

0x03 --- Read Temperature

Query

Slave address (0x01 to 0xFF)	0x03	0x00	0x03	0x00	0x01	CRC LSB	CRC MSB
---------------------------------	------	------	------	------	------	------------	------------

Response

Slave address (0x01 to 0xFF)	0x03	0x02	Register value 0x00	Register value (C/F x 10)	CRC LSB	CRC MSB
---------------------------------	------	------	------------------------	------------------------------	------------	------------

0x03 --- Read Relay_Status

Query

Slave address (0x01 to 0xFF)	0x03	0x00	0x04	0x00	0x01	CRC LSB	CRC MSB
---------------------------------	------	------	------	------	------	------------	------------

Response

Slave address (0x01 to 0xFF)	0x03	0x02	Register value 0x00	Register value (0/1)	CRC LSB	CRC MSB
---------------------------------	------	------	------------------------	-------------------------	------------	------------

0x06 --- Write single register (SENSOR_ALTITUDE)

Query

Slave address (0x01 to 0xFF)	0x06	0x00	0x05	0x00	Register value LSB*	CRC LSB	CRC MSB
---------------------------------	------	------	------	------	------------------------	------------	------------

Response

Slave address (0x01 to 0xFF)	0x06	0x00	0x05	0x00	Register value LSB*	CRC LSB	CRC MSB
---------------------------------	------	------	------	------	------------------------	------------	------------

* Registers value = 0x0000 to 0x000A, corresponding to 0 to 5,000 Feet

0x06 --- Write single register (AUTO_CAL)

Query

Slave address (0x01 to 0xFF)	0x06	0x00	0x06	0x00	Register value LSB*	CRC LSB	CRC MSB
---------------------------------	------	------	------	------	------------------------	------------	------------

Response

Slave address (0x01 to 0xFF)	0x06	0x00	0x06	0x00	Register value LSB*	CRC LSB	CRC MSB
---------------------------------	------	------	------	------	------------------------	------------	------------

* Registers value = 0x0000 to 0x0001, corresponding to 0 = OFF and 1 = ON

0x06 --- Write single register (C/F)

Query

Slave address (0x01 to 0xFF)	0x06	0x00	0x07	0x00	Register value LSB*	CRC LSB	CRC MSB
---------------------------------	------	------	------	------	------------------------	------------	------------

Response

Slave address (0x01 to 0xFF)	0x06	0x00	0x07	0x00	Register value LSB*	CRC LSB	CRC MSB
---------------------------------	------	------	------	------	------------------------	------------	------------

* Registers value = 0x0000 to 0x0001, corresponding to 0 = C and 1 = F

0x06 --- Write single register (DISPLAY_MODE)

Query

Slave address (0x01 to 0xFF)	0x06	0x00	0x08	0x00	Register value LSB*	CRC LSB	CRC MSB
---------------------------------	------	------	------	------	------------------------	------------	------------

Response

Slave address (0x01 to 0xFF)	0x06	0x00	0x08	0x00	Register value LSB*	CRC LSB	CRC MSB
---------------------------------	------	------	------	------	------------------------	------------	------------

* Registers value = 0x0000 to 0x0003, corresponding to 0 = CO2 only, 1 = CO2 + RH, 2 = CO2 + T and 3 = CO2 + RH + T

0x06 --- Write single register (TEMPERATURE_OFFSET)

Query

Slave address (0x01 to 0xFF)	0x06	0x00	0x09	0x00	Register value LSB*	CRC LSB	CRC MSB
---------------------------------	------	------	------	------	------------------------	------------	------------

Response

Slave address (0x01 to 0xFF)	0x06	0x00	0x09	0x00	Register value LSB*	CRC LSB	CRC MSB
---------------------------------	------	------	------	------	------------------------	------------	------------

* Registers value = 0x0000 to 0x0014, corresponding to -10 to +10 Degrees F

0x06 --- Write single register (RH_OFFSET)

Query

Slave address (0x01 to 0xFF)	0x06	0x00	0x0A	0x00	Register value LSB*	CRC LSB	CRC MSB
---------------------------------	------	------	------	------	------------------------	------------	------------

Response

Slave address (0x01 to 0xFF)	0x06	0x00	0x0A	0x00	Register value LSB*	CRC LSB	CRC MSB
---------------------------------	------	------	------	------	------------------------	------------	------------

* Registers value = 0x0000 to 0x0014, corresponding to -10 to +10 %RH

0x06 --- Write single register (RELAY_SETPOINT)

Query

Slave address (0x01 to 0xFF)	0x06	0x00	0x0B	0x00	Register value LSB*	CRC LSB	CRC MSB
---------------------------------	------	------	------	------	------------------------	------------	------------

Response

Slave address (0x01 to 0xFF)	0x06	0x00	0x0B	0x00	Register value LSB*	CRC LSB	CRC MSB
---------------------------------	------	------	------	------	------------------------	------------	------------

* Registers value = 0x01F4 to 0x05DC, corresponding to 500 to 1500 PPM

0x06 --- Write single register (RELAY_HYSTERESIS)

Query

Slave address (0x01 to 0xFF)	0x06	0x00	0x0C	0x00	Register value LSB*	CRC LSB	CRC MSB
---------------------------------	------	------	------	------	------------------------	------------	------------

Response

Slave address (0x01 to 0xFF)	0x06	0x00	0x0C	0x00	Register value LSB*	CRC LSB	CRC MSB
---------------------------------	------	------	------	------	------------------------	------------	------------

* Registers value = 0x0019 to 0x00C8, corresponding to 25 to 200 PPM

Exception response

Slave address (0x01 to 0xFF)	Function code + 0x80	Exception code * 0x01, 0x02 or 0x03	CRC LSB	CRC MSB
---------------------------------	-------------------------	----------------------------------------	------------	------------

* An exception response is only returned if the CRC is correct
 Exception code 01 --- illegal function, 02 --- illegal address, 03 --- illegal data value

Function codes (ASCII mode)

0x01 --- Read coil status

Query

Start character (:) 0x3A	Slave address 0x01 to 0xFF MSB	Slave address 0x01 to 0xFF LSB	Function code (0x01) MSB (0x30)	Function code (0x01) LSB (0x31)	Starting address MSB *	Starting address	Starting address	Starting address LSB
Quantity of coils MSB *	Quantity of coils	Quantity of coils	Quantity of coils LSB	LRC MSB	LRC LSB	Return-line feed (CRLF) 0x0D	Return-line feed (CRLF) 0x0A	

* Starting address = 0x0000 to 0xFFFF, Quantity of coils = 0x0000 to 0x07D0

Response

Start character (:) 0x3A	Slave address 0x01 to 0xFF MSB	Slave address 0x01 to 0xFF LSB	Function code (0x01) MSB (0x30)	Function code (0x01) LSB (0x31)	Byte count N * MSB	Byte count N LSB
Coil status MSB	...	Coil status LSB	LRC MSB	LRC LSB	Return-line feed (CRLF) 0x0D	Return-line feed (CRLF) 0x0A

* N = Quantity of coils /8 or Quantity of coils /8 +1 (if the remainder is not 0)

0x03 --- Read holding registers

Query

Start character (:) 0x3A	Slave address 0x01 to 0xFF MSB	Slave address 0x01 to 0xFF LSB	Function code (0x01) MSB (0x30)	Function code (0x01) LSB (0x33)	Starting address MSB *	Starting address	Starting address	Starting address LSB
Quantity of registers MSB *	Quantity of registers	Quantity of registers	Quantity of registers LSB	LRC MSB	LRC LSB	Return-line feed (CRLF) 0x0D	Return-line feed (CRLF) 0x0A	

* Starting address = 0x0000 to 0xFFFF, Quantity of registers = 0x0000 to 0x007D

Response

Start character (:) 0x3A	Slave address 0x01 to 0xFF MSB	Slave address 0x01 to 0xFF LSB	Function code (0x01) MSB (0x30)	Function code (0x01) LSB (0x33)	Byte count MSB *	Byte count LSB	
Register value MSB (PPM)	Register value value (PPM)	Register value value (PPM)	Register value LSB (PPM)	LRC MSB	LRC LSB	Return-line feed (CRLF) 0x0D	Return-line feed (CRLF) 0x0A

* N= Quantity of registers

0x06 --- Write single register

Query

Start character (:) 0x3A	Slave address 0x01 to 0xFF MSB	Slave address 0x01 to 0xFF LSB	Function Code (0x01) MSB (0x30)	Function Code (0x01) LSB (0x36)	Register address MSB *	Register address	Register address	Register address LSB
Register value MSB	Register value	Register value	Register value LSB	LRC MSB	LRC LSB	Return-line feed (CRLF) 0x0D	Return-line feed (CRLF) 0x0A	

* Register address = 0x0000 to 0xFFFF
Registers value = 0x0000 to 0xFFFF

Response

Start character (:) 0x3A	Slave address 0x01 to 0xFF MSB	Slave address 0x01 to 0xFF LSB	Function Code (0x01) MSB (0x30)	Function Code (0x01) LSB (0x36)	Register address MSB *	Register address	Register address	Register address LSB
Register value MSB	Register value	Register value	Register value LSB	LRC MSB	LRC LSB	Return-line feed (CRLF) 0x0D	Return-line feed (CRLF) 0x0A	

Exception response

Start character (:) 0x3A	Slave address (0x01 to 0xFF) MSB	Slave address (0x01 to 0xFF) LSB	Function Code + 0x80 MSB	Function Code + 0x80 LSB	Exception code * 0x30
Exception code * 0x01, 0x02 or 0x03 (0x31, 0x32 or 0x33)	LRC MSB	LRC LSB	Return-line feed (CRLF) 0x0D	Return-line feed (CRLF) 0x0A	

* An exception response is only returned if the LRC is correct
Exception code 01 --- illegal function, 02 --- illegal address, 03 --- illegal data value

The ASCII function codes supported by the CO2/RH/T are shown below.

0x01 --- Read CO2 Status

Query

0x3A	Slave address * 0x01 to 0xFF MSB	Slave address * 0x01 to 0xFF LSB	0x30	0x31	0x30	0x30	0x30	0x30
0x30	0x30	0x30	0x31	LRC MSB	LRC LSB	0x0D	0x0A	

* If Slave address = 0x12, then MSB = 0x31, LSB = 0x32, for example

Response

0x3A	Slave address 0x01 to 0xFF MSB	Slave address 0x01 to 0xFF LSB	0x30	0x31	0x30	0x31
0x30	Coil LSB (0x30 or 0x31)		LRC MSB	LRC LSB	0x0D	0x0A

0x03 --- Read CO2 PPM

Query

0x3A	Slave address 0x01 to 0xFF MSB	Slave address 0x01 to 0xFF LSB	0x30	0x33	0x30	0x30	0x30	0x31
0x30	0x30	0x30	0x31	LRC MSB	LRC LSB	0x0D	0x0A	

Response

0x3A	Slave address 0x01 to 0xFF MSB	Slave address 0x01 to 0xFF LSB	0x30	0x33	0x30	0x31	
Register value MSB (PPM)	Register value (PPM)	Register value (PPM)	Register value LSB (PPM)	LRC MSB	LRC LSB	0x0D	0x0A

0x03 --- Read %RH

Query

0x3A	Slave address 0x01 to 0xFF MSB (0x30)	Slave address 0x01 to 0xFF LSB	0x30	0x33	0x30	0x30	0x30	0x32
0x30	0x30	0x30	0x31	LRC MSB	LRC LSB	0x0D	0x0A	

Response

0x3A	Slave address 0x01 to 0xFF MSB	Slave address 0x01 to 0xFF LSB	0x30	0x33	0x30	0x32	
Register value 0x30	Register value 0x30	Register value (%RH)	Register value LSB (%RH)	LRC MSB	LRC LSB	0x0D	0x0A

0x03 --- Read Temperature

Query

0x3A	Slave address 0x01 to 0xFF MSB	Slave address 0x01 to 0xFF LSB	0x30	0x33	0x30	0x30	0x30	0x33
0x30	0x30	0x30	0x31	LRC MSB	LRC LSB	0x0D	0x0A	

Response

0x3A	Slave address 0x01 to 0xFF MSB	Slave address 0x01 to 0xFF LSB	0x30	0x33	0x30	0x33	
Register value 0x30	Register value 0x30	Register value (C/F x 10)	Register value LSB (C/F x 10)	LRC MSB	LRC LSB	0x0D	0x0A

0x03 --- Read Relay_Status

Query

0x3A	Slave address 0x01 to 0xFF MSB	Slave address 0x01 to 0xFF LSB	0x30	0x33	0x30	0x30	0x30	0x34
0x30	0x30	0x30	0x31	LRC MSB	LRC LSB	0x0D	0x0A	

Response

0x3A	Slave address 0x01 to 0xFF MSB	Slave address 0x01 to 0xFF LSB	0x30	0x33	0x30	0x34	
Register value 0x30	Register value 0x30	Register value (?)	Register value LSB (?)	LRC MSB	LRC LSB	0x0D	0x0A

0x06 --- Write single register (SENSOR_ALTITUDE)

Query

0x3A	Slave address 0x01 to 0xFF MSB	Slave address 0x01 to 0xFF LSB	0x30	0x36	0x30	0x30	0x30	0x35
0x30	0x30	Register value	Register value LSB	LRC MSB	LRC LSB	0x0D	0x0A	

Response

0x3A	Slave address 0x01 to 0xFF MSB	Slave address 0x01 to 0xFF LSB	0x30	0x36	0x30	0x30	0x30	0x35
0x30	0x30	Register value	Register value LSB	LRC MSB	LRC LSB	0x0D	0x0A	

0x06 --- Write single register (AUTO_CAL)

Query

0x3A	Slave address 0x01 to 0xFF MSB	Slave address 0x01 to 0xFF LSB	0x30	0x36	0x30	0x30	0x30	0x36
0x30	0x30	Register value	Register value LSB	LRC MSB	LRC LSB	0x0D	0x0A	

Response

0x3A	Slave address 0x01 to 0xFF MSB	Slave address 0x01 to 0xFF LSB	0x30	0x36	0x30	0x30	0x30	0x36
0x30	0x30	Register value	Register value LSB	LRC MSB	LRC LSB	0x0D	0x0A	

0x06 --- Write single register (C/F)

Query

0x3A	Slave address 0x01 to 0xFF MSB	Slave address 0x01 to 0xFF LSB	0x30	0x36	0x30	0x30	0x30	0x37
0x30	0x30	Register value	Register value LSB	LRC MSB	LRC LSB	0x0D	0x0A	

Response

0x3A	Slave address 0x01 to 0xFF MSB	Slave address 0x01 to 0xFF LSB	0x30	0x36	0x30	0x30	0x30	0x37
0x30	0x30	Register value	Register value LSB	LRC MSB	LRC LSB	0x0D	0x0A	

0x06 --- Write single register (DISPLAY_MODE)

Query

0x3A	Slave address 0x01 to 0xFF MSB	Slave address 0x01 to 0xFF LSB	0x30	0x36	0x30	0x30	0x30	0x38
0x30	0x30	Register value	Register value LSB	LRC MSB	LRC LSB	0x0D	0x0A	

Response

0x3A	Slave address 0x01 to 0xFF MSB	Slave address 0x01 to 0xFF LSB	0x30	0x36	0x30	0x30	0x30	0x38
0x30	0x30	Register value	Register value LSB	LRC MSB	LRC LSB	0x0D	0x0A	

0x06 --- Write single register (TEMPERATURE_OFFSET)

Query

0x3A	Slave address 0x01 to 0xFF MSB	Slave address 0x01 to 0xFF LSB	0x30	0x36	0x30	0x30	0x30	0x39
0x30	0x30	Register value	Register value LSB	LRC MSB	LRC LSB	0x0D	0x0A	

Response

0x3A	Slave address 0x01 to 0xFF MSB	Slave address 0x01 to 0xFF LSB	0x30	0x36	0x30	0x30	0x30	0x39
0x30	0x30	Register value	Register value LSB	LRC MSB	LRC LSB	0x0D	0x0A	

0x06 --- Write single register (RH_OFFSET)

Query

0x3A	Slave address 0x01 to 0xFF MSB	Slave address 0x01 to 0xFF LSB	0x30	0x36	0x30	0x30	0x30	0x41
0x30	0x30	Register value	Register value LSB	LRC MSB	LRC LSB	0x0D	0x0A	

Response

0x3A	Slave address 0x01 to 0xFF MSB	Slave address 0x01 to 0xFF LSB	0x30	0x36	0x30	0x30	0x30	0x41
0x30	0x30	Register value	Register value LSB	LRC MSB	LRC LSB	0x0D	0x0A	

0x06 --- Write single register (RELAY_SETPOINT)

Query

0x3A	Slave address 0x01 to 0xFF MSB	Slave address 0x01 to 0xFF LSB	0x30	0x36	0x30	0x30	0x30	0x42
0x30	0x30	Register value	Register value LSB	LRC MSB	LRC LSB	0x0D	0x0A	

Response

0x3A	Slave address 0x01 to 0xFF MSB	Slave address 0x01 to 0xFF LSB	0x30	0x36	0x30	0x30	0x30	0x42
0x30	0x30	Register value	Register value LSB	LRC MSB	LRC LSB	0x0D	0x0A	

0x06 --- Write single register (RELAY_HYSTERESIS)

Query

0x3A	Slave address 0x01 to 0xFF MSB	Slave address 0x01 to 0xFF LSB	0x30	0x36	0x30	0x30	0x30	0x43
0x30	0x30	Register value	Register value LSB	LRC MSB	LRC LSB	0x0D	0x0A	

Response

0x3A	Slave address 0x01 to 0xFF MSB	Slave address 0x01 to 0xFF LSB	0x30	0x36	0x30	0x30	0x30	0x43
0x30	0x30	Register value	Register value LSB	LRC MSB	LRC LSB	0x0D	0x0A	

Exception response

0x3A	Slave address (0x01 to 0xFF) MSB	Slave address (0x01 to 0xFF) LSB	Function Code * + 0x80 MSB	Function Code * + 0x80 LSB	0x30
Exception code	0x01, 0x02 or 0x03 (0x31, 0x32 or 0x33)	LRC MSB	LRC LSB	Return-line feed (CRLF) 0x0D	Return-line feed (CRLF) 0x0A

* If Function Code = 03, then MSB = 0x38, LSB = 0x33, for example

Calibration

Calibration with gas requires a field calibration kit consisting of an LCD, a bottle of 1000 ppm CO₂ gas, a tank pressure regulator with flow restrictor and the necessary tubing to connect to the device. Note that because of the Automatic Calibration Mode and other technology incorporated into the CDD series, only a single point 1000 ppm calibration is required to meet specified accuracy.

Turn the regulator on/off knob fully off and attach it to the 1000 ppm CO₂ gas bottle and firmly tighten it by hand. Remove the cover of the unit to be calibrated to expose the gas sensor chamber. The tubing from the gas bottle can be connected to either port on the chamber after the plastic cap is removed. Gently remove one cap and connect the tubing, note that strong shock or vibration can affect calibration.

Ensure the device has been operating normally for at least five minutes before applying gas. Slowly turn the valve knob on the regulator to let the gas begin flowing.

The regulator will restrict the flow rate to the specified 100 ml/min. After a brief period the gas will flow into the chamber and the CO₂ reading on the LCD will begin to approach 1000 ppm. Wait 1 to 2 minutes until the CO₂ reading stabilizes.

Enter the Setup menu and use the <MENU> key to advance to **Calibrat 1000 PPM**. Press and hold the <SAVE> key for 2 seconds and the display will change to **Waiting Calibrat** then to **Waiting 5 minute** to indicate that the process of reprogramming the internal calibration setting is taking place.

This calibration process takes about 5 minutes and the LCD will count down the minutes. Do not disturb the unit or the gas flow during this period. When calibration is complete the unit will display **Calibrat Done**. Press the <SAVE> key to return to normal operation and then the gas can be shut off. Disconnect the tubing and replace the cap on the sensor chamber as calibration is complete.

General Specifications

Power Supply 20 – 28 Vac/dc (non-isolated half-wave rectified)
Consumption 80 mA max @ 24 Vdc, 140 mA max @ 24 Vac with all options
Protection Circuitry Reverse voltage protected, overvoltage protected
Operating Conditions 0-50 °C (32-122 °F), 0-95 %RH non-condensing
Wiring Connections Screw terminal block (14 to 22 AWG)
Enclosure 5.7”w x 3.95”h x 2.5”d (145 x 100 x 63 mm)
Duct Probe 7” (177 mm) long x 1” (25.4 mm) diameter

CO2 Signal

Measurement Type Non-Dispersive Infrared (NDIR), diffusion sampling
Measurement Range 0-2000 ppm
Standard Accuracy ± 75 ppm @ 1000 ppm @ 22 °C (72 °F) compared to certified calibration gas
Temperature Dependence 0.2 %FS per °C
Stability < 2 %FS over life of sensor (15 year typical)
Pressure Dependence 0.13 % of reading per mm Hg
Altitude Correction Programmable from 0-5000 ft via ModBus
Response Time < 2 minutes for 90 % step change typical
Warm-up Time < 2 minutes

Interface

Hardware 2-wire RS-485
Software Native ModBus MS/TP protocol (RTU or ASCII)
Baud Rate Locally set to 300, 600, 1200, 2400, 4800, 9600, 19200, 38400, 57600, 76800 or 115200
Slave Address Range Locally set to 1-255 (factory default is 1), (255 devices max on one daisy chain)

LCD Display

Resolution 1 ppm CO2, 1 %RH, 0.1 °C (0.1 °F)
Size 1.4” w x 0.6” h (35 x 15 mm) alpha-numeric 2 line x 8 characters
Backlight Enable or disable via keypad

Optional Temperature Signal

Sensing Element 10K thermistor, ± 0.4 °F (± 0.2 °C)
Resolution 0.2 °F (0.1 °C)
Range 32-95 °F (0-35 °C)

Optional RH Signal

Sensor Thermoset polymer based capacitive
Accuracy ± 2 %RH
Range 0-100 %RH, non-condensing
Resolution 1 %RH
Hysteresis ± 3 %RH
Response Time 15 seconds typical
Stability ± 1.2 %RH typical @ 50 %RH in 5 years

Optional Relay Output

Contact Ratings Form A contact (N.O.), 2 Amps @ 140 Vac, 2 Amps @ 30 Vdc
Relay Trip Point Programmable 500-1500 ppm via ModBus
Relay Hysteresis Programmable 25-200 ppm via ModBus

